

## 2-Way Diaphragm Valve,

**Forged stainless steel body,  
manually operated**



### Description

Series 20 manually operated diaphragm valve has a flow-optimized stainless steel body, a diaphragm, a bonnet and manual handle. The stainless steel body is available with various surface finish. The diaphragm is both a switch as well as a sealing element for the media. It is easily replaceable. The bonnet is provided for the protection of diaphragm and handle-mechanism. Flow can be continually adjusted with proper positioning of the handle. Position indicator is provided at top of the handle. This valve is designed for zero dead leg and can be mounted to be self-draining. This allows high flow capacity and variety of applications.

### Main Features

- Cavity free and self-draining
- Hermetical separation of fluids from the operating mechanism by diaphragm
- Fully machined from SS 316L bar-stock– no welded components
- Fully Autoclavable
- Full traceability as per EN 10204 3.1 and ASME BPE
- Various internal surface finish available each with less than 0.40 Ra

## Dimensions

2-Way diaphragm valve, forged stainless steel body, manually operated  
Body with Butt-weld End

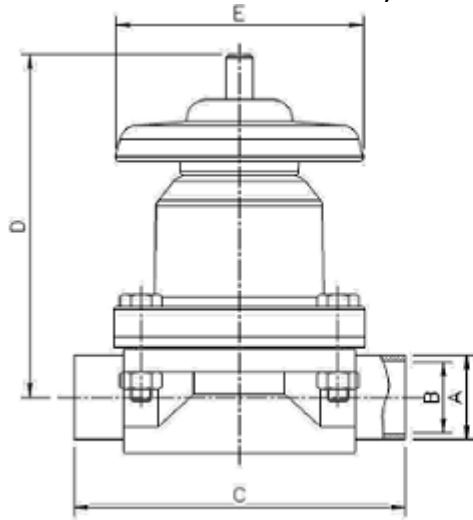

Figure 20-1 Bonnet & handle- Stainless Steel

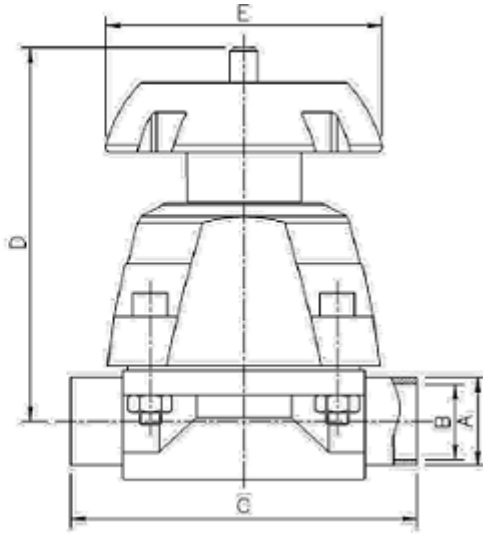

Figure 20-2 Bonnet & handle- Polyamide

Figure 20-1 Bonnet & handle- Stainless Steel

Connection Size	Flange OD	Pipe ID	Face to face length	Max. Valve Height From Pipe Center	Outside Diameter of Handle
	A [mm]	B [mm]	C [mm]	D [mm]	E [mm]
1/2" mini	12.70	9.40	70.0	69.5	40.0
1/2" Regular	12.70	9.40	84.0	78.3	59.5
3/4"	19.05	15.75	84.0	81.4	59.5
1"	24.50	22.10	108.0	103.5	91.0
1 1/2"	38.10	34.80	131.0	137.7	109.5
2"	50.80	47.50	131.0	144.5	109.5
2 1/2"	63.50	60.20	154.0	162.1	152.0
3"	76.20	72.90	154.0	168.0	152.0

Figure 20-2 Bonnet & handle- Polyamide

Connection Size	Flange OD	Pipe ID	Face to face length	Max. Valve Height From Pipe Center	Outside Diameter of Handle
	A [mm]	B [mm]	C [mm]	D [mm]	E [mm]
1/2" Regular	12.70	9.4	84.0	88.3	79.0
3/4"	19.05	15.75	84.0	91.4	79.0
1"	24.50	22.1	108.0	110.8	93.0
1 1/2"	38.10	34.8	131.0	130.1	116.5
2"	50.80	47.5	131.0	136.9	116.5
2 1/2"	63.50	60.2	154.0	170.0	149.0
3"	76.20	72.9	154.0	176.0	149.0

- No position indicator available for this valve

2-Way diaphragm valve, forged stainless steel body, manually operated

Body with V-band (Hygienic) Clamp Connector

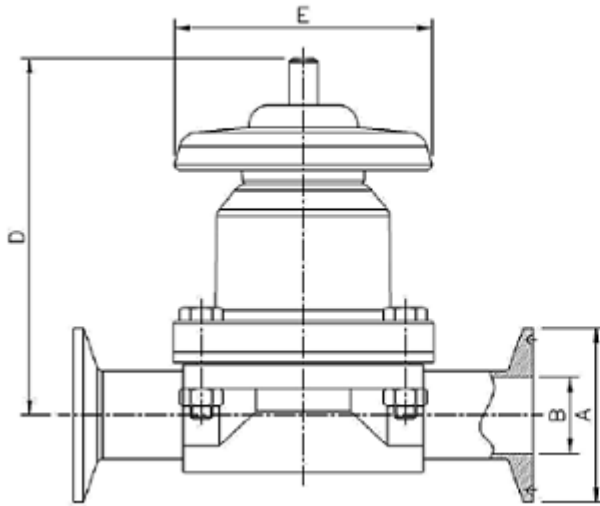

Figure 20-3 Bonnet & handle- Stainless Steel

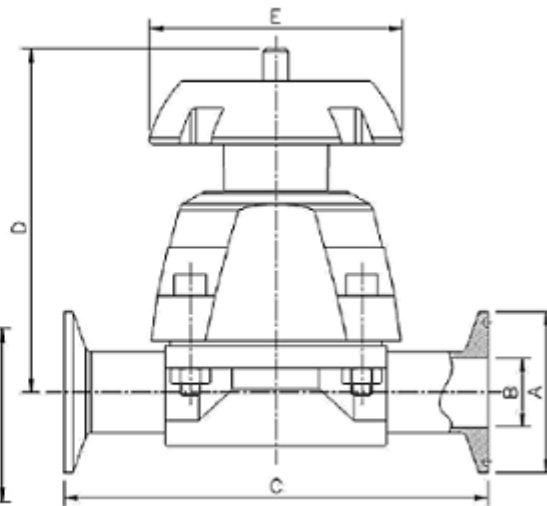

Figure 20-4 Bonnet & handle- Polyamide

Figure 20-3 Bonnet & handle- Stainless Steel

Connection Size	Flange OD	Pipe ID	Face to face length	Max. Valve Height From Pipe Center	Outside Diameter of Handle
	A [mm]	B [mm]	C [mm]	D [mm]	E [mm]
1/2" mini	25.00	9.4	95.5	69.5	40.0
1/2" Regular	25.00	9.4	109.5	78.5	59.5
3/4"	50.40	15.75	109.5	81.4	59.5
1"	50.40	22.10	133.5	103.5	91.0
1 1/2"	50.40	34.80	156.5	137.7	109.5
2"	63.90	47.50	156.5	144.5	109.5
2 1/2"	77.40	60.20	179.5	162.1	152.0
3"	90.90	72.90	179.5	168.0	152.0

- No position indicator available for this valve

Figure 20-4 Bonnet & handle- Polyamide

Connection Size	Flange OD	Pipe ID	Face to face length	Max. Valve Height From Pipe Center	Outside Diameter of Handle
	A [mm]	B [mm]	C [mm]	D [mm]	E [mm]
1/2" Regular	25.00	9.4	109.5	88.3	79.0
3/4"	50.40	15.75	109.5	91.4	79.0
1"	50.40	22.1	133.5	110.8	93.0
1 1/2"	50.40	34.8	156.5	130.1	116.5
2"	63.90	47.5	156.5	136.9	116.5
2 1/2"	77.40	60.2	179.5	170.0	149.0
3"	90.90	72.9	179.5	176.0	149.0

Notes:

1. For V-band (Hygienic) clamp connections, clamp connector will be welded to the valve body with butt-weld end. Internal finish will be provided as per customer's request.
2. Dimensions and tolerances for end connection and face-to-face length are as per ASME BPE.
3. All other dimensions are approximate and subject to change without prior notice
4. Dimensions for valve with stainless steel bonnet and polyamide handle will be provided on request

## Technical Data

### Processing medium

Neutral gases and liquids, high purity, sterile, aggressive or abrasive fluids

### Temperature

Media temperature		Sterilization temperature		Ambient Temperature
EPDM	-10°C to 75°C	EPDM	Briefly up to 130°C	Up to 90°C
PTFE	-10°C to 90°C	PTFE	Briefly up to 150°C	

Diaphragm size	Operating pressure [bar]	
	EPDM	PTFE
8	0 - 8	0 - 6

All pressures are gauge pressures. Operating pressure values were determined with static operating pressure applied on one side of a closed valve. Sealing at the valve seat and atmospheric sealing is ensured for the given values. Information on operating pressures applied on both sides and for high purity media on request.

### Valve body material

MOC – Wetted (Contact)	MOC – Non-wetted (Non- contact)
Stainless steel 316L	Polyamide or ASTM A351 CF8 (SS 304)

### End connection

V-band (Hygienic) Clamp	ASME BPE
Butt-Weld	(EN ISO 1127/ISO 4200 and BS 4825 are available on request)

### Installation

Installation for self draining mounting	Tilted 10°C to 35°C to the horizontal and inclined 3°C to 5°C to the direction of flow
---	--

## Data Order

M5	1/2" Mini
R5	1/2" Regular
07	3/4"
10	1"
15	1 1/2"
20	2"
25	2 1/2"
30	3"

Type of Diaphragm	
EPDM	E
PTFE	P

Certificate	
ISO 9001	9
ISO 9001 + 'CE' (PED 97/23/EC)	p <sup>1</sup>

Connection Type	
ASME BPE	A
BS 4825	B
EN ISO 1127 / ISO 4200	E <sup>2</sup>

Type of End Connection	
Butt Weld	B
V- Band (hygienic) Clamp	T

Surface Finish	
Mechanical Polish	M
Electro Polish	E

Bonnet & handle Material of Construction <sup>3</sup>	
ASTM A351 GR CF8	C
Polyamide	P

Order Example	LE	20	A	10	E	P	P	E	B	9
Leistung										
Series #										
Conn. Type										
Conn. Size										
Type of diaphragm										
Bonnet										
Handle										
Surface finish										
Type of end conn.										
Certificate										

### Notes:

- 'CE'-marking is applicable for valves with connection sizes 1 1/2", 2", 2 1/2" and 3" only.
- EN ISO 1127/ISO 4200 offers standards for butt-weld end connections only.
- Combination of polyamide bonnet and steel handle (LE10XXXXPCXXX) is not available.
- Valves with end connection sizes according to EN ISO 1127/ISO 4200 and BS 4825 are available on request

Contact: [sales@titanresearch.ca](mailto:sales@titanresearch.ca)  
<https://www.titangroupsupply.com/>

Tell: 1-800-820-0092

Fax: 1-416-849-0116

For further diaphragm valves, gaskets, compatible actuators & accessories and other products, please contact us for pricing.